



Gamma Thickness Gauge



New 4 High Mill



Four High Mill Modernization

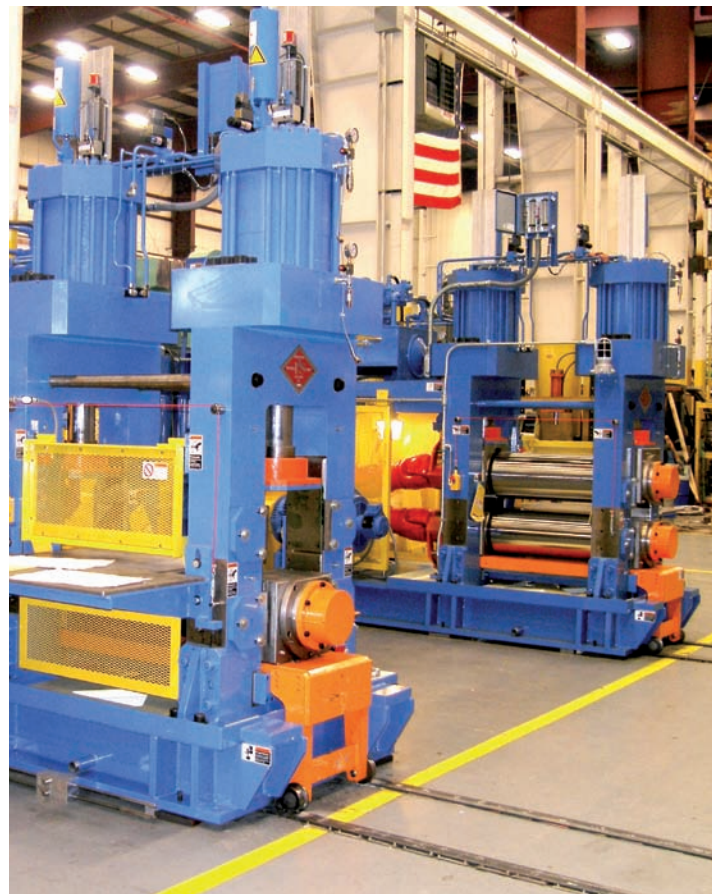

New 2 High Mills



Tenova I2S
I2S, LLC
475 Main Street
Yalesville, CT 06492-1723 - USA
Phone +1 203 265 5684
Fax +1 203 284 1819
sales@i2s.com

I2S Trade (Shanghai) Co. Ltd.
Apollo Building, Room #511
1440 Yan An Road (C)
Shanghai, 200040 - China
Phone +86 21 62483170
Fax +86 21 62483063
sales@i2strade.com

Tenova STRIP PROCESSING
Tenova SpA
Via Monte Rosa, 93
20149 Milan - Italy
Phone +39 02 43847785
Fax +39 02 43847621
stripprocessing@it.tenovagroup.com

POMINI Tenova
Tenova SpA
Via Leonardo da Vinci, 20
21053 Castellanza (VA) - Italy
Phone +39 0331 444356
Fax +39 0331 444390
pomini@it.tenovagroup.com

www.tenovagroup.com

TECHINT GROUP

Tenova CORE
Core Furnace Systems Corp.
Cherrington Corporate Center
100 Corporate Center Drive
Coraopolis, PA 15108-3185 - USA
Phone +1 412 262 2240
Fax +1 412 262 2055
info@corefurnace.com

Tenova LOI IITALIMPIANTI
LOI Thermprocess GmbH
Am Lichtbogen 29
45141 Essen - Germany
Phone +49 201 1891 1
Fax +49 201 1891 321
info@loi-italimpianti.de



Tenova is a world-wide supplier of advanced technologies, products and services for the metal and mining industries providing innovative integrated solutions. Combined process automation and metallurgical know-how enhance the value delivered to the customers. Tenova is committed further to develop its technology in the areas that mostly impact the future of the industries it serves: quality of the products delivered by the customers, energy savings and environmental safeguard.



Advanced Cold Rolling Mills

6 High, 4 High, 2 High

TENOVA is a world-wide supplier of advanced technologies, products and services for the metal and mining industries.

Tenova I2S has established a global reputation as a world leader in the design and supply of cold rolling mills. With 40 years experience as cold mill specialists, Tenova I2S provides cost effective system solutions that exceed market expectations for flat products. Tenova I2S employs an analytical rolling mill design method to ensure an optimum mill solution for the specific customer product mix.

Tenova I2S offers expertise, designs and supplies of Six High, Four High, and Two High Reversing and Non Reversing Mills as stand alone, double stand, and tandem mills, as coil to coil, or as part of in-line processes, single stand, in the following configurations to suit the specific needs of the product and application:

Six High Configuration (Reversing and Non-reversing) with Intermediate Roll Shifting and horizontal stabilization specially designed for ultra thin production, AFC System, HAGC Control, Multi-zone Strip Cooling, Positive and Negative Roll Bending, Quick Roll Changing Systems, and Strip Drying System on demand.

Four High Configuration (Reversing and Non-reversing) with AFC System, HAGC Control, Multi-zone Strip Cooling, Positive and Negative Roll Bending, Quick Roll Changing Systems, and Strip Drying System on demand.

Two High Mills used for skin pass operation or as reduction rolling of soft materials having narrow width. As skinpass, they are used for roughness transfer, for specific tempering, for elongation, or surface finish. Two high can have additional shape and thickness control capability by adding external chocks with bending system.

Temper or Skin Pass Mills: two high, four high, six high configuration, dry or wet rolling, for cold and hot rolled coils, to provide specific surface conditions, metallurgical and mechanical improvement characteristics. The skinpass mill can be proposed as off-line coil to coil mill or can be installed into a processing line such as galvanizing, pickling, annealing, cut to length, and tension leveling lines.

Bonding Mills and Specialty Mills, used to fuse different material types and special metals into single clad strip for minting and electronics applications. Applications include Embossing, and Skiving.

Mill Modernization by Tenova I2S target increased Mill operation efficiencies, improved productivity and strip quality. Our modernizations cover the full range of Mechanical, Electrical, Automation and Control systems. The typical Tenova I2S modernization scheme includes supply of Automation & Mill Control, AGC, SPC, HMI, PLC, Drives, Hydraulic Roll Force conversion, and mechanical upgrades.

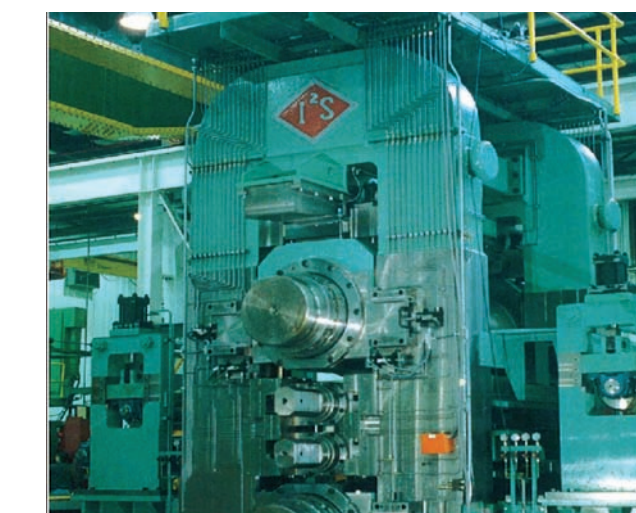
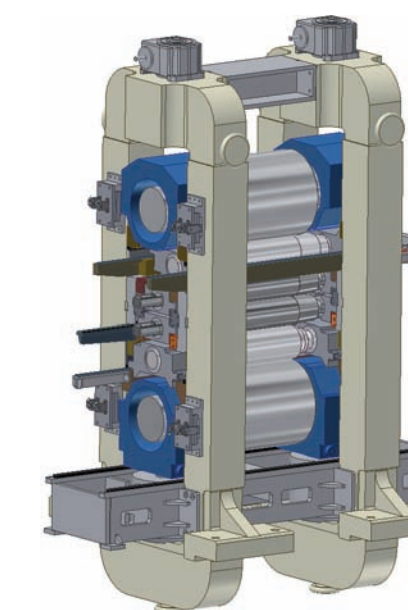

Entry section

Left Side

Rolling Process - Reversing Mill

Right Side

Side View

Entry section

- Coil Storage
- Coil Lift & Transfer
- Payoff with Outboard Mandrel Support & Driven Hold-down Roll
- Coil Peeler
- Strip centering, Payoff Positioning
- Feeder / Leveler
- Thread Table

Left Side

- Coil Storage
- Coil Lift & Transfer
- Payoff with Outboard Mandrel Support & Driven Hold-down Roll
- Coil Peeler
- Strip centering, Payoff Positioning
- Feeder / Leveler
- Thread Table

Mill Stand: 6 High, 4 High or 2 High

- Four Hi Reversing Mill shown with:
- Hydraulic Force Cylinder (HAGC)
- Hydraulic Roll Bending / Roll Shifting
- Hydraulic Counterbalance
- Pass Line Adjustment
- Backup Roll Changer
- Quick Roll Changer

Right Side

- Shear
- Strip Wipers
- Strip Thickness Gauge
- Shape Measurement Roll with Load Cell Tensiometer
- Pinch Roll
- Flipper Table
- Tension Reel with Outboard Mandrel Support Driven Hold-down Roll, & Stripper Plate
- Coil Lift & Transfer
- Belt Wrapper



Payoff Mill Stand Coolant System

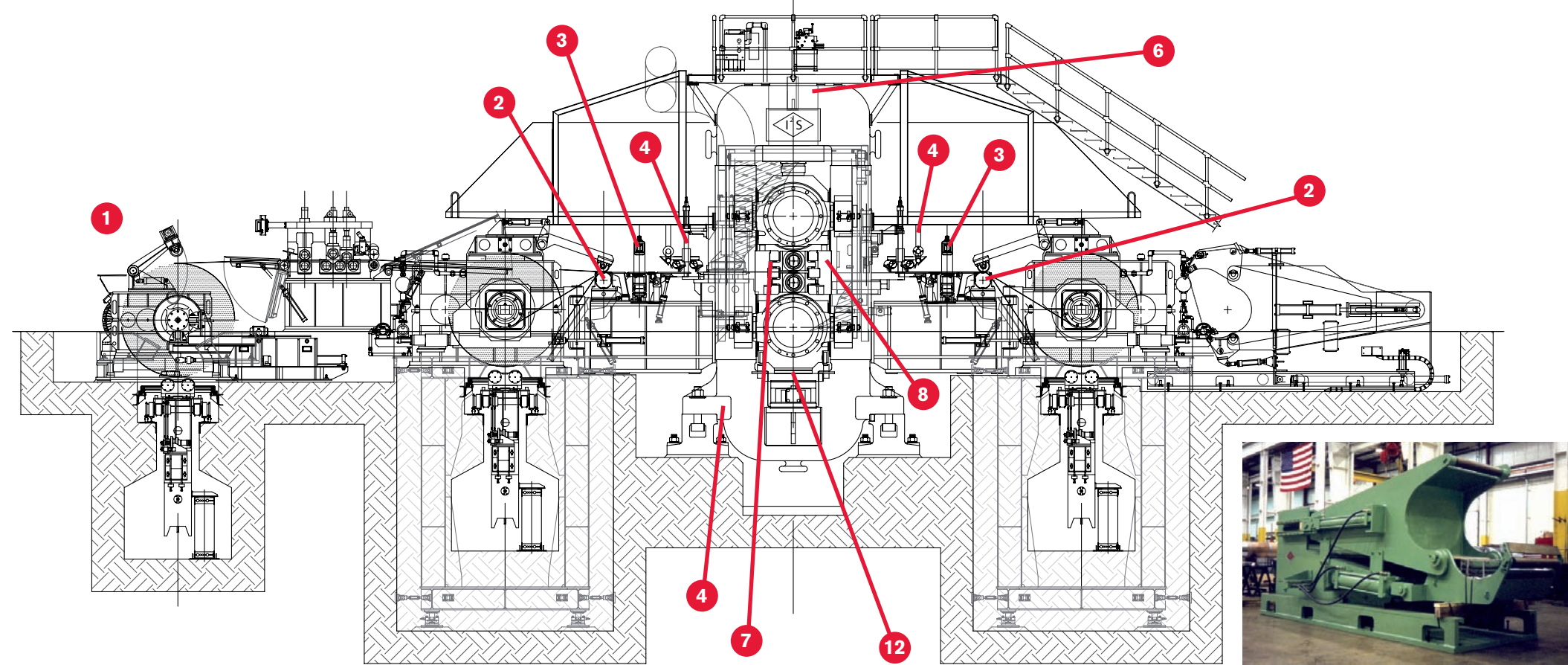

- 1. Payoff**
Moveable with automatic center-guide system. Auto loading of coil onto mandrel
- 2. Deflector / Shape Roll**
with Load Cells to provide accurate regulation of strip tension and shape

- 3. Tenova I2S Strip Thickness Gauges**
Measures accurate thickness of strip
- 4. Air Blowoffs**
for removal of coolant from strip
- 5. Mill Stand (4Hi Mill Shown)**

- 6. Hydraulic Roll Force Cylinders**
HAGC System
- 7. Roll Bending / Shifting**
with Interface to shape system
- 8. Thermal Crown Control**
with Interface to shape system

- 9. Belt Wrapper**
Used for initially wrapping the leading end of thin strip around the Tension Reel Mandrel

- 10. Roll Changer**
Hydraulic Side Shifting changer allows quick roll changing
- 11. Back-up Roll Changer**
Hydraulic Actuation

- 12. Pass Line Adjustment**
Hydraulically Operated Continuous Wedge
- 13. Mill Stand**
AC/DC Drives can be configured to drive either Work Rolls, or Backup Rolls

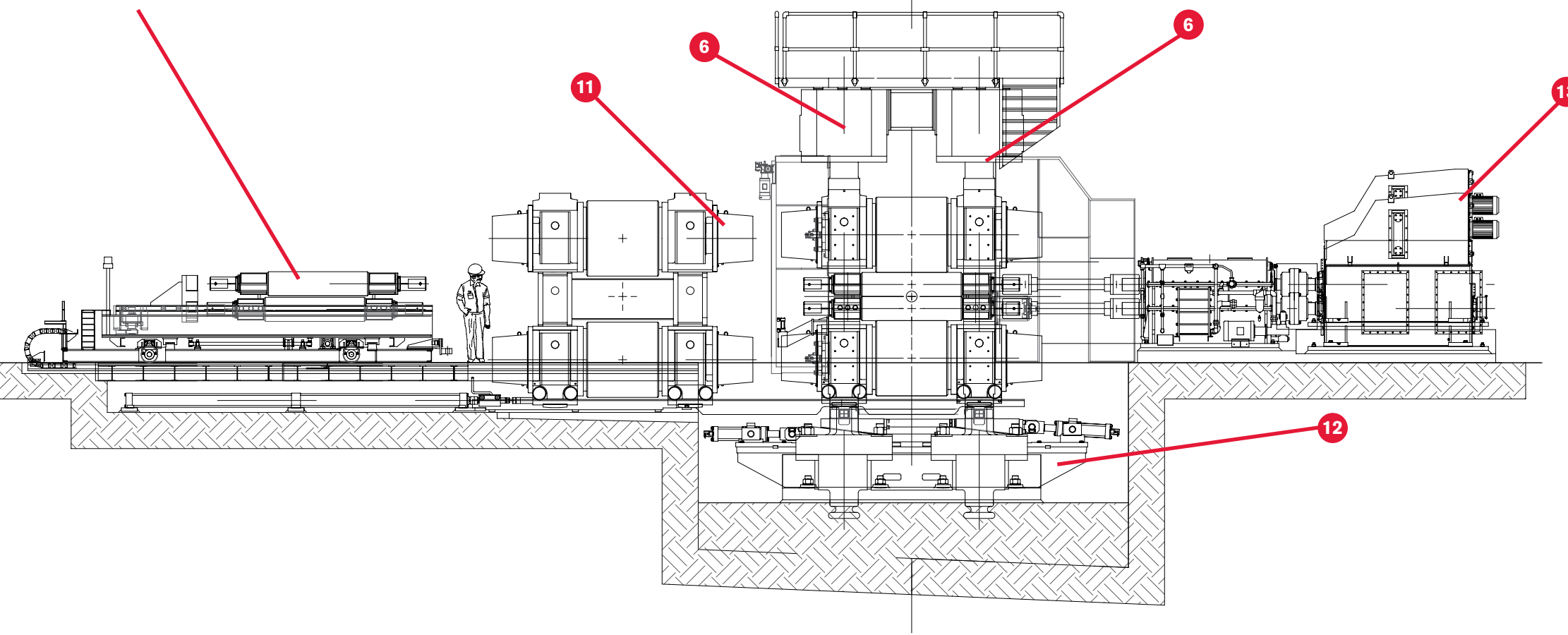

The Tenova I2S mill automation systems are designed to offer a broad range of capabilities, from narrowly defined, surgical modernization projects...to...comprehensive, fully integrated control, automation and drive system, including high level production supervision, planning and support. Each system implementation is highly customized to facilitate the needs and requirements of the mill and end-user / customer.

The system architecture is based on a flexible / modular organization that is implemented by a network interconnected, multi-computer, distributed control system concept. The system hierarchy spans the classical Level 0 (instrumentation & actuation) through Level 2+ (operational management & production support), and offers sophisticated interfacing with Level 3+ systems.

The highly networked nature of this architecture provides extensive information sharing among the system's components, where these components have been designed for flexible application and interfacing, thereby allowing them to function in stand-alone operations to actively participating in fully integrated, comprehensive mill control and automation systems.

Typical components in a comprehensive, fully integrated mill control and automation system include:

Level 0

- Instrumentation, Sensing & Actuation
- Strip Thickness Measurement
- Strip Tension, Speed / Length Measurement
- Strip Shape / Flatness Measurement
- Power Conversion & Drive Systems

Level 1

- Mill Master Control
- Network Systems
- Automation Databases
- Drive Control / Coordination (Strip Transport & Tension Control)
- Precision Servo Controls
- Automatic Strip Thickness Control (AGC)
- Automatic Strip Shape / Flatness Control (AFC)
- Graphical User Interfaces (HMI)
- Engineering Data Logging & Analysis (IBA)
- Maintenance Support & Remote Accessibility

Level 2

- Mill Management
- Production Support
- Pass & Shape Target Scheduling
- Mathematical Modeling
- Performance & Engineering Reporting
- SPC / QC Quality Analysis & Reporting
- Production & Mill Operations Reporting
- Database Historian
- Roll Cluster Modeling & Set-Up
- Level 3+ Interfacing