



Open Cast Mining Equipment

TENOVA is a world-wide supplier of advanced technologies, products and services for the metal and mining industries



Tenova is a world-wide supplier of advanced technologies, products and services for the metal and mining industries providing innovative integrated solutions. Combined process automation and metallurgical know-how enhance the value delivered to the customers.

Tenova is committed further to develop its technology in the areas that mostly impact the future of the industries it serves: quality of the products delivered by the customer, energy saving and environmental safeguard.

Tenova TAKRAF specializes in the engineering and supply of open-pit mining and bulk materials handling equipment. It provides complete systems, as well as individual machines, to clients all over the world, in all climatic conditions.

Open Cast Mining Equipment

Tenova TAKRAF is one of the world's leading suppliers in the fields of mining and handling of coal, ore and other minerals, as well as removal, transport and dumping of overburden.

Tenova TAKRAF machines and systems have proved to be reliable in mining the hardest minerals, even under extreme operating conditions.

The extensive know-how of our highly qualified engineers creates a solid foundation for the construction of such machinery.

Rapid delivery and constant high quality are guaranteed by Tenova TAKRAF's policy of close cooperation with the clients and decades of experience of the computer-aided development, design and manufacture of surface mining equipment and systems.



It was back in 1924 that we supplied our first overburden conveying bridge to the surface mine at Plessa in Germany.

The first bucket wheel excavators developed and produced by our company were delivered to the Consolidated Diamond Mines in Namibia in 1926.

Nowadays, more than 50% of world lignite production is mined with Tenova TAKRAF equipment.

The combination of know-how and the large number of completed machines and systems coupled with constant orientation to the state-of-the-art means that optimal technology and equipment can be offered for each geological situation.



Open Cast Mining Equipment - Product Range

Tenova TAKRAF supplies complete open cast mining systems

- Bucket wheel excavators
- Bucket chain excavators
- Mobile transfer conveyors
- Belt conveyors (curved, shiftable, down hill, etc.)
- Tripper cars
- Spreaders/ Cross-pit spreaders
- Mobile Conveyor bridges
- Mobile and semi-mobile crushing stations
- Surface miners
- Transport crawlers
- Heap-Leach Systems
- Auxiliary surface mining equipment and reclamation equipment





Open Cast Mining Equipment

Depending on their size, Tenova TAKRAF's newly compact bucket wheel excavators (BWEs) can achieve capacities of up to 75,000 m³ per day. Our new line-up of models in the large and giant BWE class offers daily capacities of up to 240,000 m³.

A large variety of possible combinations of these machines with especially matched spreaders and belt conveyor systems, as well as cross-pit spreaders, ensures effective, cost saving operations.

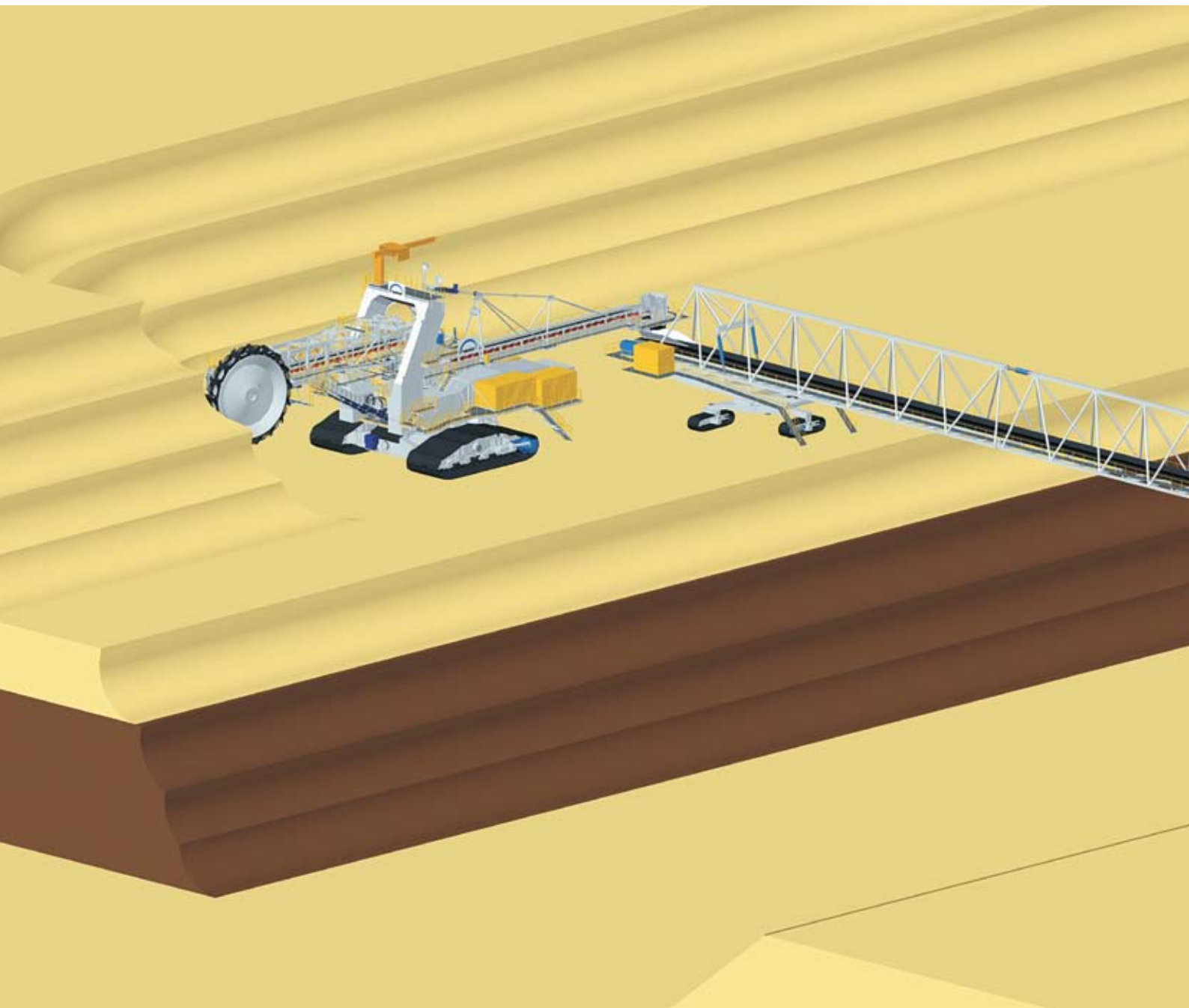

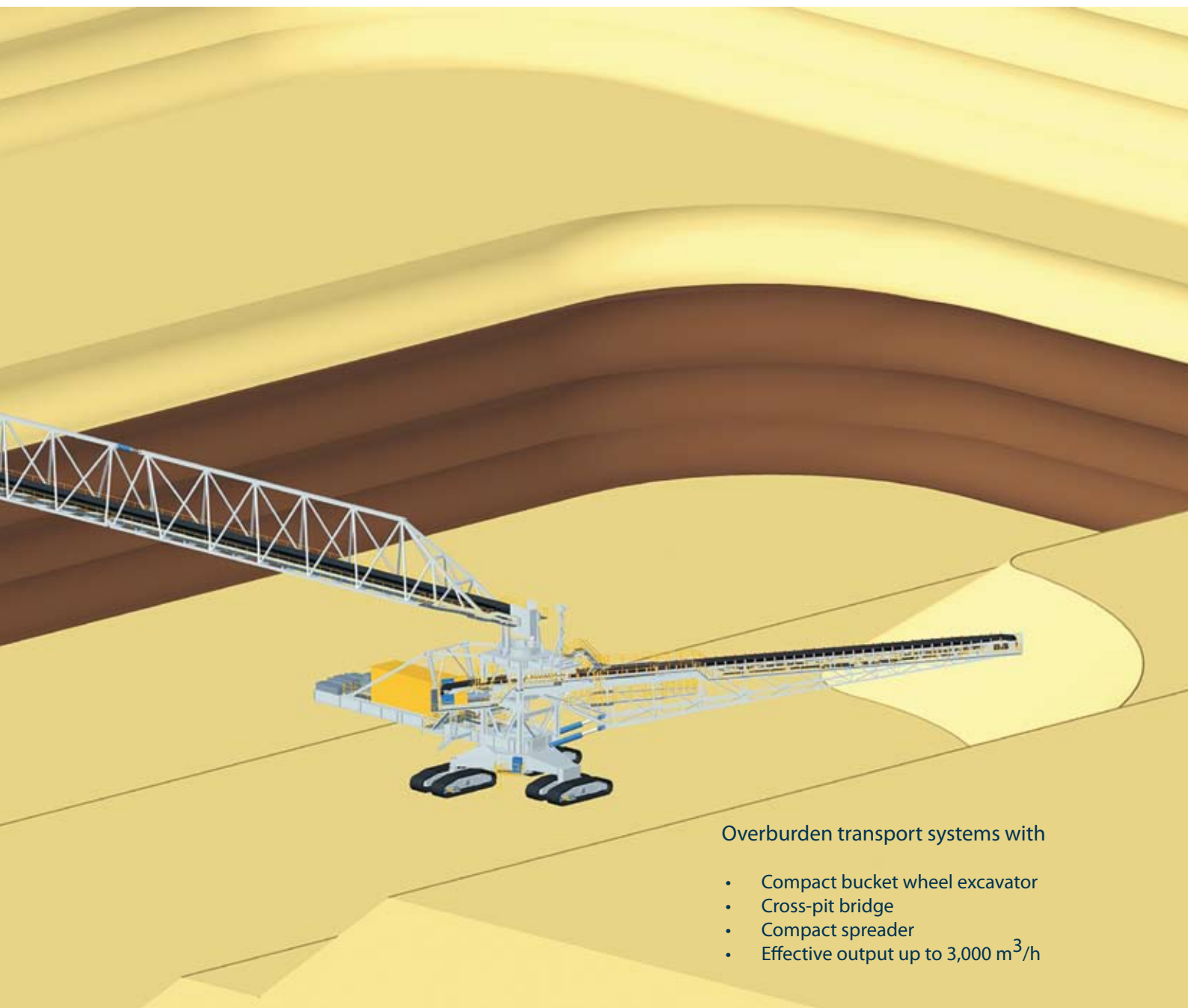

Overburden transport systems with

- Compact bucket wheel excavator
- Cross-pit bridge
- Compact spreader
- Effective output up to 3,000 m³/h



In cross-pit operation up to 240,000 m³ of overburden per day can be shifted using different combinations of our machines.

Furthermore, Tenova TAKRAF machinery has proved to be highly reliable under the world's toughest geological conditions and working environments. All units, systems and plants can be supplied for use in low-temperature areas down to -45°C minimum.

Overburden transport systems with

- Compact bucket wheel excavator
- Cross-pit spreader



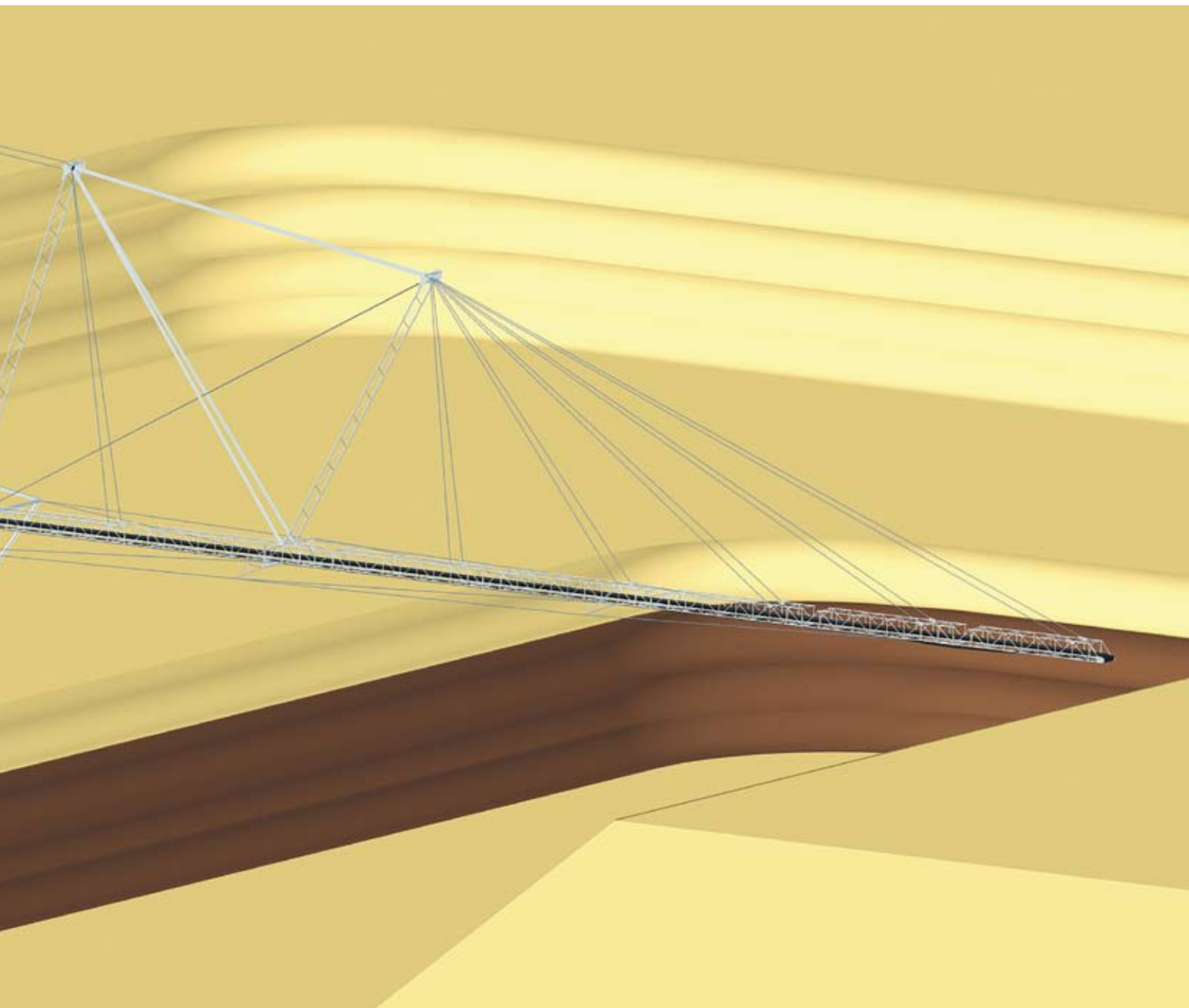

Tenova TAKRAF systems guarantee the following benefits to the client:

- optimum adaptation to the geological and technical requirements of earthworks and surface mining operations, thanks to Tenova TAKRAF's own R & D capacities
- low investment
- the use of proven and standardised structural components
- high availability
- simple maintenance
- low operating costs

We perform project studies on

- complete new surface mining operations
- the expansion and modernisation of existing surface mines
- the refurbishment of surface mining installations
- the conversion and transfer of mining systems

Tenova TAKRAF plans and supplies the best combinations of machinery for surface mines with

- cross-pit operation
- belt conveyor operation
- conveying bridge operation

The low-maintenance design of Tenova TAKRAF plant and machine systems, our comprehensive service and the short delivery of spare parts guarantee that Tenova TAKRAF equipment is economical and can work efficiently and reliably year after year.

Overburden transport systems with

- Rope shovel
- Mobile crushing plant
- Hopper car
- Mobile transfer conveyor
- Belt conveyor system
- Tripper car
- Compact spreader

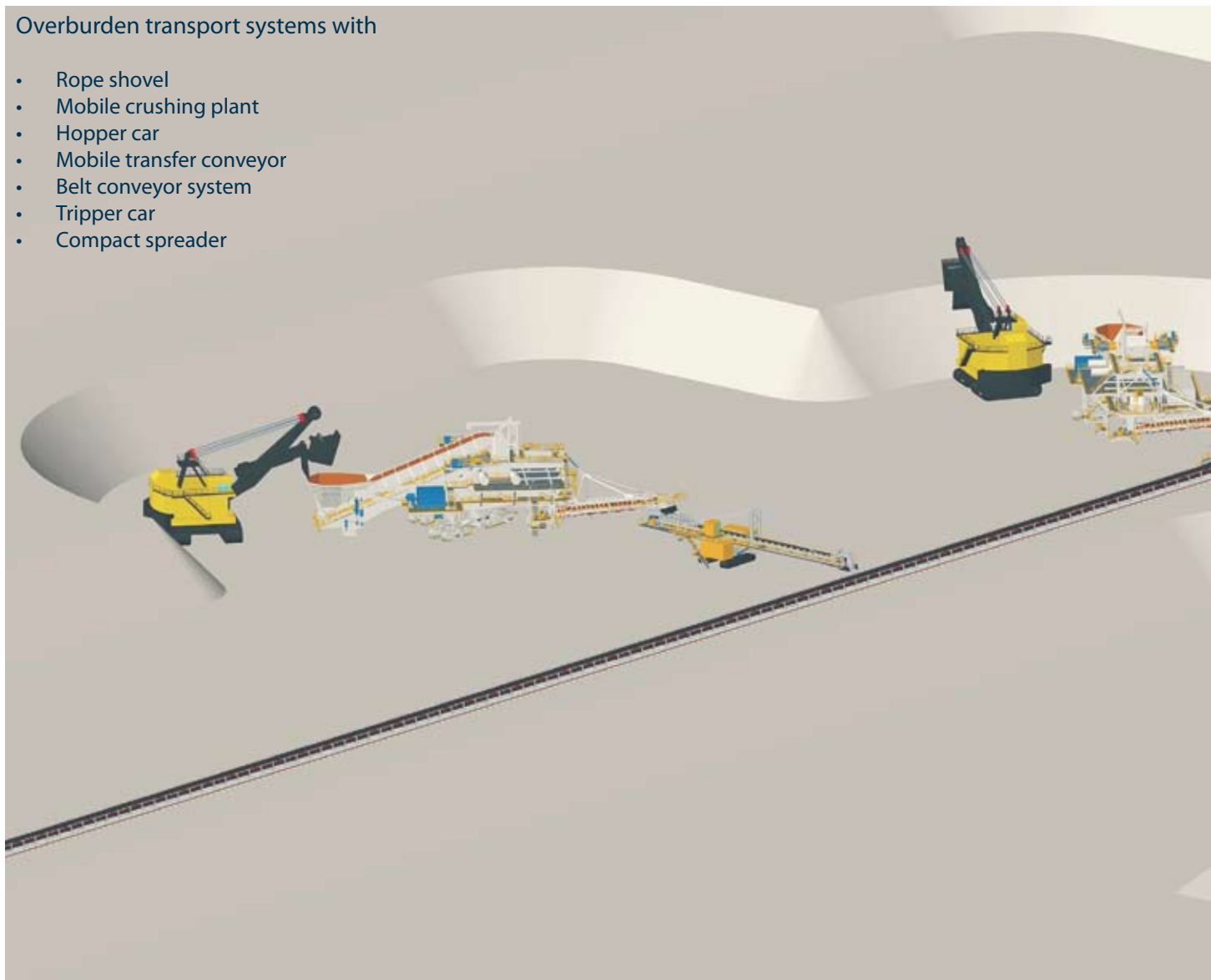

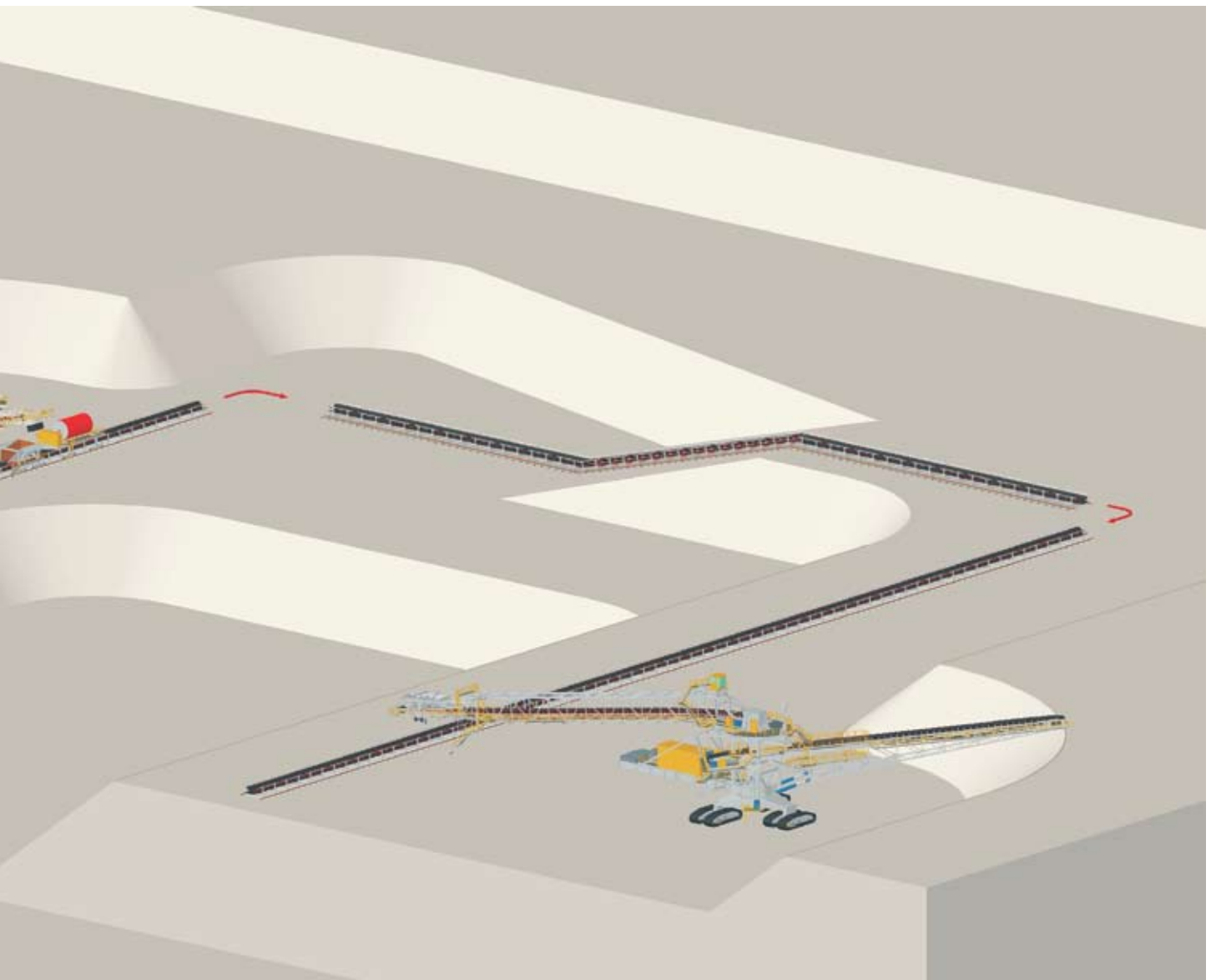

Products and Services

Open Cast Mining Equipment

- Complete open cast mining systems
- Bucket wheel excavators
- Bucket chain excavators
- Surface Miners
- Mobile transfer conveyors
- Conveyor systems (overland, curved, shiftable, inclined, etc.)
- Slope conveyor bridges
- Spreaders/Cross pit spreaders
- Mobile conveyor bridges
- Mobile and semi-mobile crushing stations
- Transport crawlers
- Heap-Leach Systems

Bulk Materials Handling Equipment

- Bulk materials handling systems
- Stackers
- Reclaimers
- Stacker/reclaimers
- Scraper reclaimers
- Ship loaders
- Continuous ship unloaders
- Grab type ship unloaders
- Tube conveyors
- Waggon tippers

Fabrication/Technical Service

- Component supplies
- Service, Maintenance
- Work farmed out by other industrial contractors
- Work assemblies
- Erection
- Quality assurance
- Operational assistance
- Inspection





Tenova TAKRAF

TAKRAF GmbH
Torgauer Straße 336
04347 Leipzig
Germany
phone +49 341 2423 500
fax +49 341 2423 510
sales@takraf.com

Bahnhofstraße 26
01979 Lauchhammer
Germany
phone +49 3574 854 0
fax +49 3574 854 100
service@takraf.com

Tenova S.p.A
Torre Shipping
Via De Marini, 53
16149 Genoa
Italy
phone +39 010 6054067
fax +39 010 6054710
bulkhandling@it.tenovagroup.com

www.takraf.com
www.tenovagroup.com

TECHINT GROUP